

COMPOSITE DECKING FIXING GUIDELINES

COMPOSITE DECKING FIXING INSTRUCTIONS



This guide will help you when choosing the type of fixings to use, where to place the fixings and other practical recommendations.

GUIDANCE FROM METSÄ WOOD :

In addition to the manufacturers fixing instructions (shown overleaf), the following notes highlight specific guidance from Metsä Wood:

Wood Composite deck boards are subject to expansion and contraction when exposed to variations in temperature. To accommodate for this potential thermal movement:

Allow a 30mm expansion gap around the perimeter of the deck giving consideration to all walls, posts and other obstacles.

Allow a 10mm expansion gap between the ends of boards

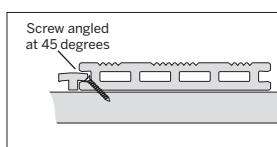

To prevent 'creep' secret fix each board with a single screw, positioned half way along its length, angled at 45 degrees and fixed through the bottom lip of the groove and into the joist or bearer below.

In addition:

- To aid water run off prepare the sub-frame to accommodate a fall of 2mm per metre along the length of the deck boards.
- Fix joists/bearers at a maximum of 40cm centres when boards are fitted perpendicular to the joist direction. When boards are fitted diagonal to the direction of the joist/bearer provide supports at 30cm centres.
- If the deck is to be raised or used for commercial use, seek guidance from a qualified engineer to ensure the structure is sufficient to carry the potential loading.

COMPOSITE DECKING – MANUFACTURERS FIXING INSTRUCTIONS

Prior to laying: Preferably to be used on a hard sub-grade. In case of use directly on garden soil always place paving stones underneath the rails to create an extra strong foundation (see image 1). In that case level the ground first and remove possible weeds and use a black anti-weed membrane to prevent as much as possible weeds from growing. Keep a minimum gap of 30 mm between decking / rails and walls or other obstacles. In order to absorb the longitudinal effect of the WPC decking by influence of temperature changes, please keep an opening of about 10 mm between the crosscut faces in case of use of several sections of decking in the longitudinal direction of the terrace. Use a fine-toothed saw for cutting the material to size.

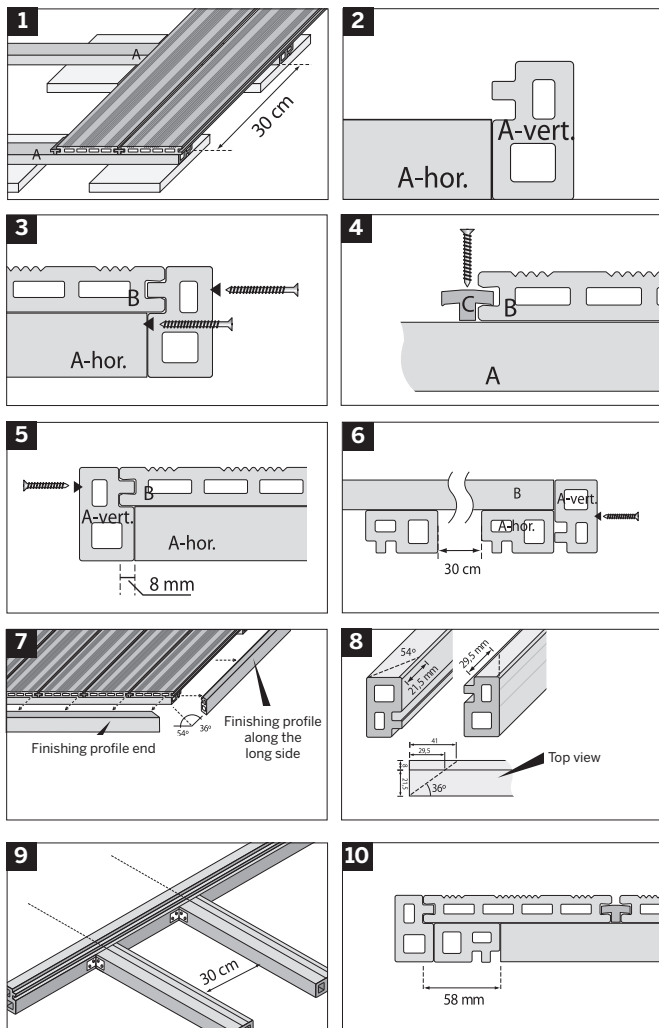

**NOTE: NOT SUITABLE FOR
LOAD-BEARING STRUCTURES.**

STEP 1

Lay the rails (base structure) flat and level (see image 6), at a maximum interval of 40 cm.

TIP: KEEP DECKING 2-3 CM LONGER AND CUT TO SIZE AFTER INSTALLATION, USING A CIRCULAR SAW. THEN FIT THE FINISHING PROFILE. THIS WILL GIVE IT A VERY NEAT FINISH.

STEP 2.

Place a finishing profile (A-vertical) against the head of the rails (A-horizontal), see image 2. Cut this finishing profile with a false mitre. Note: follow the drawing (see images 7 and 8), so that the finishing profile connects with the so-called crosscut face later. This too must be done exactly according to the drawing (see images 7 and 8).

STEP 3.

Now install the first section of decking (B). Make sure that the tongue of the finishing profile and the groove of the decking interlock and connect correctly. Now screw the finishing profile to the decking into the marked v-grooves every other 40 cm, using the enclosed long screws. Beware of the power of your electric screwdriver (see image 3).

TIP: FOR ADDITIONAL STABILITY, THE HORIZONTAL RAILS CAN BE SCREWED ONTO THE VERTICAL FINISHING PROFILE USING ANGLE IRONS (SEE IMAGE 9)

STEP 4.

When the first section is in place, place a clip (C) on each rail, in the groove of the decking. Make sure they connect well and then (semi-) tighten/untighten the clips to the rail, using the enclosed short screws (see image 4). You can now install the second section and repeat the above instructions until you have created the size of terrace you want. Once the entire terrace is in place, tighten all screws and clips (beware of the power of your electric screwdriver).

STEP 5.

Once the final section is in place, you finish with a finishing profile (A-vertical) on both the longitudinal side and the so-called crosscut face. Now cut the longitudinal side of the profile to be connected with a false mitre. Note: follow the drawing (see images 7 and 8), so that the finishing profile connects with the crosscut face later. Make sure that the rails (A-horizontal) are cut to the right length, so that the decking slightly protrudes (by about 8 mm) and the finishing profile connects nicely (see image 5). Now screw the finishing profile to the decking into the marked v-grooves every other 40 cm, using the enclosed long screws (see image 5).

TIP: For an extra neat and strong attachment of the finishing profile, we recommend you attach another bottom rail to the crosscut faces of the bottom rail at a right angle, using the angle irons as described under step 3. In that case you must keep the bottom rails $50 + 8 = 58$ mm shorter than the end of the last section of decking. Once the last section is in place, you can fully secure the finishing profile (see image 10).

Before securing the finishing profile to the crosscut face, please note the following:

- make sure you "turn" the profile in relation to the profile on the longitudinal side before you start cutting (see image 6).
- now follow the drawing (see images 7 and 8), and cut the connecting finishing profile for the crosscut face with a false mitre.
- then screw the finishing profile to the underlying rail into the marked v-groove every other 40cm, using the enclosed long screws (see image 6).

TIP: BEWARE OF THE POWER OF YOUR ELECTRIC SCREWDRIVER.